

# chapter 20 ELECTRIC CIRCUITS

For help with these problems

[www.tutor-homework.com](http://www.tutor-homework.com)

Be sure to mention the filename:

Physics\_Questions\_0023

[www.tutor-homework.com](http://www.tutor-homework.com) (for tutoring, homework help, or help with online classes)

## Section 20.1 Electromotive Force and Current

### Section 20.2 Ohm's Law

- 1. Which one of the following situations results in a conventional electric current that flows westward?
  - (a) a beam of protons moves eastward
  - (b) an electric dipole moves westward
  - (c) a beam of electrons moves westward
  - (d) a beam of electrons moves eastward
  - (e) a beam of neutral atoms moves westward
  
- 2. Complete the following statement: The electromotive force is
  - (a) the maximum potential difference between the terminals of a battery.
  - (b) the force that accelerates electrons through a wire when a battery is connected to it.
  - (c) the force that accelerates protons through a wire when a battery is connected to it.
  - (d) the maximum capacitance between the terminals of a battery.
  - (e) the maximum electric potential energy stored within a battery.
  
- 3. How many electrons flow through a battery that delivers a current of 3.0 A for 12 s?
  - (a) 4
  - (b) 36
  - (c)  $4.8 \times 10^{15}$
  - (d)  $6.4 \times 10^{18}$
  - (e)  $2.2 \times 10^{20}$
  
- 4. A 10-A current is maintained in a simple circuit with a total resistance of 200  $\Omega$ . What net charge passes through any point in the circuit during a 1-minute interval?
  - (a) 200 C
  - (b) 400 C
  - (c) 500 C
  - (d) 600 C
  - (e) 1200 C
  
- 5. Which one of the following combinations of units is equivalent to the ohm?
  - (a) V/C
  - (b) A/J
  - (c) J/s
  - (d) J-s/C<sup>2</sup>
  - (e) W/A
  
- 6. The potential difference across the ends of a wire is doubled in magnitude. If Ohm's law is obeyed, which one of the following statements concerning the resistance of the wire is true?
  - (a) The resistance is one half of its original value.
  - (b) The resistance is twice its original value.
  - (c) The resistance is not changed.
  - (d) The resistance increases by a factor of four.
  - (e) The resistance decreases by a factor of four.
  
- 7. Which one of the following circuits has the largest resistance?

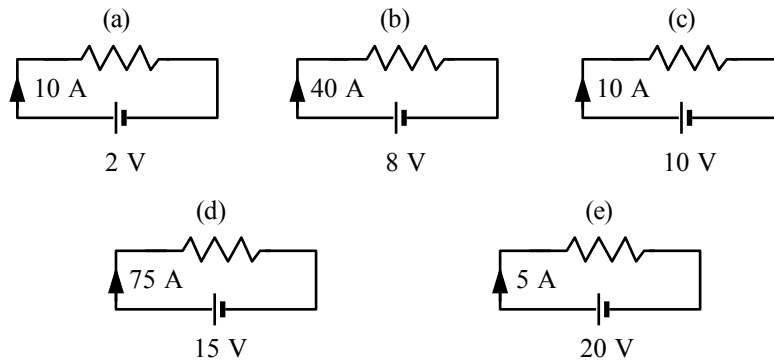

9. When a light bulb is connected to a 4.5 V battery, a current of 0.16 A passes through the bulb filament. What is the resistance of the filament?
- (a) 440  $\Omega$  (c) 9.3  $\Omega$  (e) 0.72  $\Omega$   
 (b) 28  $\Omega$  (d) 1.4  $\Omega$

### Section 20.3 Resistance and Resistivity

10. Which one of the following statements concerning resistance is true?
- (a) The resistance of a semiconductor increases with temperature.  
 (b) Resistance is a property of resistors, but not conductors.  
 (c) The resistance of a metal wire changes with temperature.  
 (d) The resistance is the same for all samples of the same material.  
 (e) The resistance of a wire is inversely proportional to the length of the wire.
11. Which one of the following statements concerning superconductors is false?
- (a) Below its critical temperature, the resistivity of a superconductor is zero  $\Omega$ -m.  
 (b) Critical temperatures for some superconductors exceed 100 K.  
 (c) All materials are superconducting at temperatures near absolute zero kelvin.  
 (d) A constant current can be maintained in a superconducting ring for several years without an emf.  
 (e) Superconductors are perfect conductors.
12. Determine the length of a copper wire that has a resistance of 0.172  $\Omega$  and cross-sectional area of  $1 \times 10^{-4} \text{ m}^2$ . The resistivity of copper is  $1.72 \times 10^{-8} \Omega \cdot \text{m}$ .
- (a) 0.1 m (c) 100 m (e) 10 000 m  
 (b) 10 m (d) 1000 m
14. Which one of the wires carries the smallest current when they are connected to identical batteries?
- (a) wire E (c) wire C (e) wire A  
 (b) wire D (d) wire B
15. Of the five wires, which one has the smallest resistance?
- (a) wire A (c) wire C (e) wire E  
 (b) wire B (d) wire D
16. Which one of the five wires has the largest resistance?
- (a) wire A (c) wire C (e) wire E  
 (b) wire B (d) wire D

**Section 20.4 Electric Power**

17. Complete the following statement: The unit *kilowatt · hour* measures
- (a) current. (c) power. (e) voltage.  
(b) energy. (d) potential drop.
18. Which one of the following quantities can be converted to kilowatt · hours (kWh)?
- (a) 2.0 A (c) 5.8 J (e) 6.2 C/V  
(b) 8.3 V (d) 9.6 W
19. The current through a certain heater wire is found to be fairly independent of its temperature. If the current through the heater wire is doubled, the amount of energy delivered by the heater in a given time interval will
- (a) increase by a factor of two. (d) decrease by a factor of four.  
(b) decrease by a factor of two. (e) increase by a factor of eight.  
(c) increase by a factor of four.
20. A 4-A current is maintained in a simple circuit with a total resistance of 2  $\Omega$ . How much energy is delivered in 3 seconds?
- (a) 3 J (c) 12 J (e) 96 J  
(b) 6 J (d) 24 J
21. A 40-W and a 60-W light bulb are designed for use with the same voltage. What is the ratio of the resistance of the 60-W bulb to the resistance of the 40-W bulb?
- (a) 1.5 (c) 2.3 (e) 3.0  
(b) 0.67 (d) 0.44
22. A 5-A current is maintained in a simple circuit that consists of a resistor between the terminals of an ideal battery. If the battery supplies energy at a rate of 20 W, how large is the resistance?
- (a) 0.4  $\Omega$  (c) 2  $\Omega$  (e) 8  $\Omega$   
(b) 0.8  $\Omega$  (d) 4  $\Omega$
23. A computer monitor uses 2.0 A of current when it is plugged into a 120 V outlet. The monitor is never turned off. What is the yearly cost of operating the monitor if the cost of electricity is \$0.12/kWh?
- (a) \$14 (c) \$98 (e) \$250  
(b) \$21 (d) \$170
24. A resistor dissipates 1.5 W when it is connected to a battery with a potential difference of 12 V. What is the resistance of the resistor?
- (a) 0.13  $\Omega$  (c) 18  $\Omega$  (e) 96  $\Omega$   
(b) 220  $\Omega$  (d) 8.0  $\Omega$

**Section 20.5 Alternating Current**

25. An ac current has an rms value of 3.54 A. Determine the peak value of the current.
- (a) 1.25 A (c) 3.75 A (e) 7.08 A  
(b) 2.50 A (d) 5.00 A

- 26. A  $220\text{-}\Omega$  resistor is connected across an ac voltage source  $V = (150\text{ V}) \sin [2\pi(60\text{ Hz})t]$ . What is the average power delivered to this circuit?
- (a) 51 W (c) 280 W (e) 550 W  
 (b) 110 W (d) 320 W
- 27. A lamp uses an average power of 55 W when it is connected to an *rms* voltage of 120 V. Which entry in the following table is correct for this circuit?
- |     | lamp resistance $R$ ( $\Omega$ ) | $I_{rms}$ (A) |
|-----|----------------------------------|---------------|
| (a) | 260                              | 0.46          |
| (b) | 22                               | 3.8           |
| (c) | 130                              | 0.65          |
| (d) | 170                              | 0.57          |
| (e) | 38                               | 1.2           |
- 28. When a 1500-W hair dryer is in use, the current passing through the dryer may be represented as  $I = (17.7\text{ A}) \sin (120\pi t)$ . What is the rms current for this circuit?
- (a) 17.7 A (c) 85.7 A (e) 8.85 A  
 (b) 12.5 A (d) 25.0 A

**Questions 29 through 33 pertain to the situation described below:**

The figure shows variation of the current through the heating element with time in an iron when it is plugged into a standard 120 V, 60 Hz outlet.

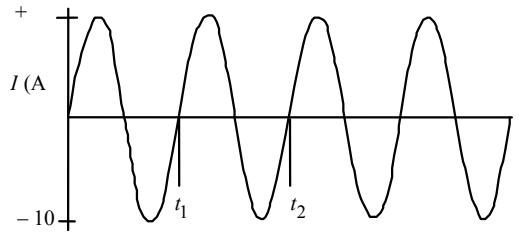

- 29. What is the peak voltage?
- (a) 10 V (c) 120 V (e) 240 V  
 (b) 60 V (d) 170 V
- 30. What is the *rms* value of the current in this circuit?
- (a) 1.4 A (c) 11 A (e) 18 A  
 (b) 7.1 A (d) 14 A
- 31. What is the resistance of the iron?
- (a) 24  $\Omega$  (c) 17  $\Omega$  (e) 1.8  $\Omega$   
 (b) 7.1  $\Omega$  (d) 12  $\Omega$
- 32. If  $t_1 = 0.050$  s, what is the value of  $t_2$ ? **Note:** The origin for the graph is not necessarily at  $t = 0$  s.
- (a) 0.067 s (c) 0.10 s (e) 61 s  
 (b) 0.079 s (d) 0.60 s
- 33. What is the approximate average power dissipated in the iron?
- (a) 450 W (c) 850 W (e) 1700 W  
 (b) 600 W (d) 1200 W



### Section 20.6 Series Wiring

- 34. Which one of the following statements concerning resistors in series is true?
- The voltage across each resistor is the same.
  - The current through each resistor is the same.
  - The power dissipated by each resistor is the same.
  - The rate at which charge flows through each resistor depends on its resistance.
  - The total current through the resistors is the sum of the current through each resistor.
- 35. Two wires, **A** and **B**, and a variable resistor, **R**, are connected in series to a battery. Which one of the following results will occur if the resistance of **R** is increased?
- The current through **A** and **B** will increase.
  - The voltage across **A** and **B** will increase.
  - The voltage across the entire circuit will increase.
  - The power used by the entire circuit will increase.
  - The current through the entire circuit will decrease.
- 36. Three resistors, 50- $\Omega$ , 100- $\Omega$ , 200- $\Omega$ , are connected in series in a circuit. What is the equivalent resistance of this combination of resistors?
- 350  $\Omega$
  - 250  $\Omega$
  - 200  $\Omega$
  - 120  $\Omega$
  - 29  $\Omega$

- 37. A 4.5-V battery is connected to two resistors connected in series as shown in the drawing. Determine the total power dissipated in the resistors.
- 0.033 W
  - 0.090 W
  - 0.15 W
  - 0.60 W
  - 4.7 W

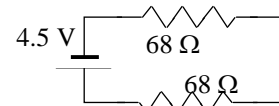

- 38. Two 15- $\Omega$  and three 25- $\Omega$  light bulbs and a 24 V battery are connected in a series circuit. What is the current that passes through each bulb?
- 0.23 A
  - 0.51 A
  - 0.96 A
  - 1.6 A
  - The current will be 1.6 A in the 15- $\Omega$  bulbs and 0.96 A in the 25- $\Omega$  bulbs.

### Section 20.7 Parallel Wiring

- 39. Complete the following statement: A simple series circuit contains a resistance  $R$  and an ideal battery. If a second resistor is connected in parallel with  $R$ ,
- the voltage across  $R$  will decrease.
  - the current through  $R$  will decrease.
  - the total current through the battery will increase.
  - the rate of energy dissipation in  $R$  will increase.
  - the equivalent resistance of the circuit will increase.

- 40. Some light bulbs are connected in parallel to a 120 V source as shown in the figure. Each bulb dissipates an average power of 60 W. The circuit has a fuse **F** that burns out when the current in the circuit exceeds 9 A. Determine the largest number of bulbs, which can be used in this circuit without

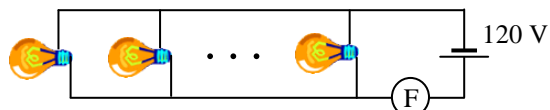

burning out the fuse.

- (a) 9
- (b) 17
- (c) 25
- (d) 34
- (e) 36

41. Two resistors are arranged in a circuit that carries a total current of 15 A as shown in the figure. Which one of the entries in the following table is correct?

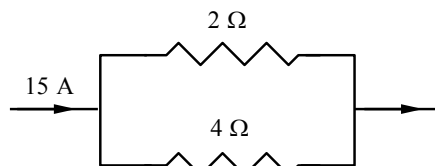

	<u>Current through 2-Ω resistor</u>	<u>Voltage across 4-Ω resistor</u>
(a)	5 A	10 V
(b)	5 A	20 V
(c)	10 A	20 V
(d)	15 A	15 V
(e)	10 A	10 V

42. What is the total power dissipated in the two resistors in the circuit shown?

- (a) 10 W
- (b) 15 W
- (c) 33 W
- (d) 67 W
- (e) 670 W

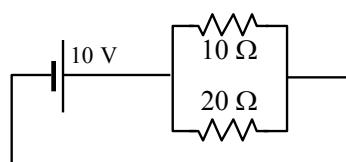

43. Three resistors, 6.0-Ω, 9.0-Ω, 15-Ω, are connected in parallel in a circuit. What is the equivalent resistance of this combination of resistors?

- (a) 30 Ω
- (b) 10 Ω
- (c) 3.8 Ω
- (d) 2.9 Ω
- (e) 0.34 Ω

**Section 20.8 Circuits Wired Partially in Series and Partially in Parallel**

44. Five resistors are connected as shown. What is the equivalent resistance between points A and B?

- (a) 6.8 Ω
- (b) 9.2 Ω
- (c) 3.4 Ω
- (d) 2.1 Ω
- (e) 16 Ω

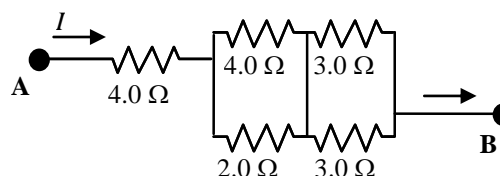

45. Jason's circuit has a 24-Ω resistor that is connected in series to two 12-Ω resistors that are connected in parallel. JoAnna's circuit has three identical resistors wired in parallel. If the equivalent resistance of Jason's circuit is the same as that of JoAnna's circuit, determine the value of JoAnna's resistors.

- (a) 90 Ω
- (b) 48 Ω
- (c) 30 Ω
- (d) 24 Ω
- (e) 12 Ω

Questions 46 through 48 pertain to the statement and diagram below:

Three resistors are connected as shown in the figure. The potential difference between points A and B is 26 V.

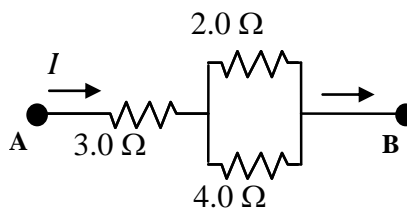

46. What is the equivalent resistance between the points A and B?
- (a) 3.8 Ω
  - (b) 4.3 Ω
  - (c) 5.1 Ω
  - (d) 6.8 Ω
  - (e) 9.0 Ω

- 47. How much current flows through the 3- $\Omega$  resistor?  
 (a) 2.0 A (c) 6.0 A (e) 10.0 A  
 (b) 4.0 A (d) 8.7 A
- 48. How much current flows through the 2- $\Omega$  resistor?  
 (a) 2.0 A (c) 6.0 A (e) 10.0 A  
 (b) 4.0 A (d) 8.7 A

*Questions 49 through 51 pertain to the statement and diagram below:*

Four resistors and a 6-V battery are arranged as shown in the circuit diagram.

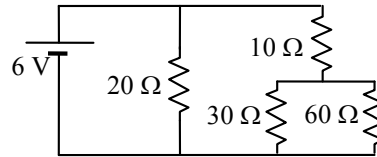

- 49. Determine the equivalent resistance for this circuit.  
 (a) 50  $\Omega$  (c) 29  $\Omega$  (e) 12  $\Omega$   
 (b) 120  $\Omega$  (d) 5  $\Omega$
- 50. The smallest current passes through which resistor(s)?  
 (a) the 10- $\Omega$  resistor (d) the 60- $\Omega$  resistor  
 (b) the 20- $\Omega$  resistor (e) It is the same and the smallest in the 30- $\Omega$  and 60- $\Omega$  resistors.  
 (c) the 30- $\Omega$  resistor
- 51. The largest potential difference is across which resistor(s)?  
 (a) the 10- $\Omega$  resistor (d) the 60- $\Omega$  resistor  
 (b) the 20- $\Omega$  resistor (e) It is the same and the largest for the 30- $\Omega$  and 60- $\Omega$  resistors.  
 (c) the 30- $\Omega$  resistor

*Questions 52 through 55 pertain to the statement and diagram below:*

Three resistors are placed in a circuit as shown. The potential difference between points **A** and **B** is 30 V.

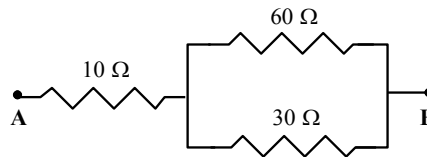

- 52. What is the equivalent resistance between the points **A** and **B**?  
 (a) 10  $\Omega$  (c) 30  $\Omega$  (e) 100  $\Omega$   
 (b) 20  $\Omega$  (d) 50  $\Omega$
- 53. What is the potential drop across the 10- $\Omega$  resistor?  
 (a) 10 V (c) 30 V (e) 100 V  
 (b) 20 V (d) 60 V
- 54. What is the potential drop across the 30- $\Omega$  resistor?  
 (a) 10 V (c) 30 V (e) 100 V  
 (b) 20 V (d) 60 V
- 55. What is the current through the 30- $\Omega$  resistor?

- (a) 0.3 A
- (b) 0.5 A
- (c) 0.7 A
- (d) 1 A
- (e) 2 A

**Section 20.9 Internal Resistance**

- 56. A non-ideal battery has a 6.0-V *emf* and an internal resistance of 0.6 Ω. Determine the terminal voltage when the current drawn from the battery is 1.0 A.

  - (a) 5.0 V
  - (b) 6.0 V
  - (c) 5.4 V
  - (d) 6.6 V
  - (e) 5.8 V
  
- 57. A battery has a terminal voltage of 12 V when no current flows and an internal resistance of 2 Ω. The battery is placed in series with a 1-Ω resistor. Which one of the entries in the following table is correct?

	<u>Terminal voltage</u>	<u>Current through the 1-Ω resistor</u>
(a)	4 V	4 A
(b)	4 V	12 A
(c)	12 V	4 A
(d)	12 V	12 A
(e)	18 V	3 A
  
- 58. A battery is manufactured to have an *emf* of 24.0 V, but the terminal voltage is only 22.0 V when the battery is connected across a 7.5-Ω resistor. What is the internal resistance of the battery?

  - (a) 3.2 Ω
  - (b) 0.27 Ω
  - (c) 1.2 Ω
  - (d) 0.75 Ω
  - (e) 0.68 Ω

**Section 20.10 Kirchhoff's Rules**

- 59. Three resistors are connected in a circuit as shown. Using Kirchhoff's rules, determine the current in one of the 16-Ω resistors.

  - (a) 0.50 A
  - (b) 0.75 A
  - (c) 1.0 A
  - (d) 1.3 A
  - (e) 2.0 A

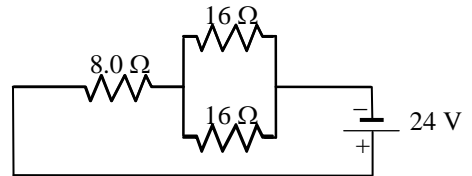

- 60. Three resistors and two 10.0-V batteries are arranged as shown in the circuit diagram. Which one of the following entries in the table is correct?

	<u>Power Delivered by Battery 1</u>	<u>Power Delivered by Battery 2</u>
(a)	2.5 W	2.5 W
(b)	4.0 W	1.0 W
(c)	1.0 W	1.0 W
(d)	1.0 W	4.0 W
(e)	4.0 W	4.0 W

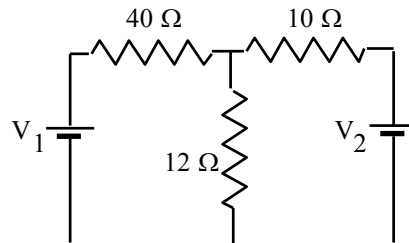



61. Three resistors and two batteries are connected as shown in the circuit diagram. What is the magnitude of the current through the 12-V battery?
- (a) 0.15 A  
 (b) 0.82 A  
 (c) 0.30 A  
 (d) 0.67 A  
 (e) 0.52 A

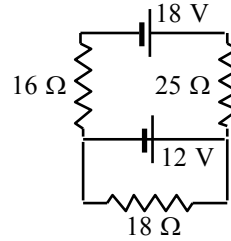

62. Determine the power dissipated by the 40-Ω resistor in the circuit shown.
- (a) 3.6 W  
 (b) 4.5 W  
 (c) 9.0 W  
 (d) 14 W  
 (e) 27 W

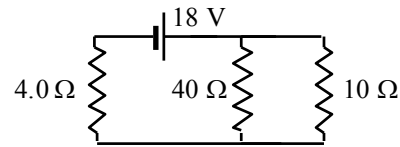

*Questions 63 through 67 pertain to the statement and diagram below:*

Five resistors are connected as shown in the diagram. The potential difference between points **A** and **B** is 25 V.

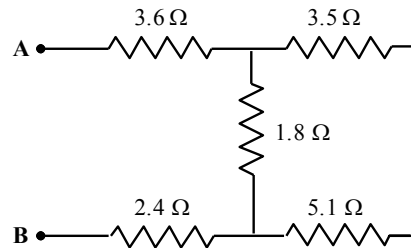

63. What is the equivalent resistance between the points **A** and **B**?
- (a) 1.5 Ω  
 (b) 4.8 Ω  
 (c) 7.5 Ω  
 (d) 9.4 Ω  
 (e) 11 Ω
64. What is the current through the 3.6-Ω resistor?
- (a) 1.3 A  
 (b) 3.3 A  
 (c) 6.9 A  
 (d) 7.5 A  
 (e) 25 A
65. What is the current through the 1.8-Ω resistor?
- (a) 2.8 A  
 (b) 3.3 A  
 (c) 5.6 A  
 (d) 6.9 A  
 (e) 14 A
66. How much energy is dissipated in the 1.8-Ω resistor in 4.0 seconds?
- (a) 18 J  
 (b) 28 J  
 (c) 55 J  
 (d) 64 J  
 (e) 93 J
67. What is the potential drop across the 3.5-Ω resistor?
- (a) 2.0 V  
 (b) 5.0 V  
 (c) 8.0 V  
 (d) 17 V  
 (e) 25 V

*Questions 68 through 71 pertain to the statement and diagram below:*

Five resistors are connected as shown in the diagram. The potential difference between points **A** and **B** is 15 V.

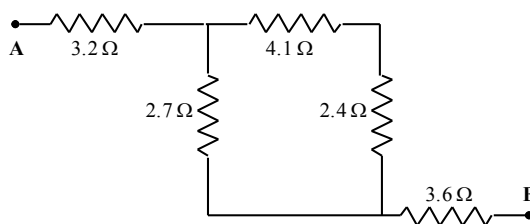

- 68. What is the equivalent resistance between the points **A** and **B**?
- (a) 1.5 Ω (c) 8.7 Ω (e) 11.1 Ω  
 (b) 4.8 Ω (d) 10.4 Ω
- 69. What is the current in the 3.6-Ω resistor?
- (a) 1.3 A (c) 2.9 A (e) 15 A  
 (b) 1.7 A (d) 3.5 A
- 70. What is the current in the 2.7-Ω resistor?
- (a) 12 A (c) 2.2 A (e) 1.2 A  
 (b) 0.8 A (d) 0.4 A
- 71. What amount of energy is dissipated in the 2.7-Ω resistor in 9.0 seconds?
- (a) 15 J (c) 29 J (e) 52 J  
 (b) 24 J (d) 36 J

### Section 20.12 Capacitors in Series and Parallel

- 72. Which one of the following statements is true concerning capacitors of *unequal capacitance* connected in series?
- (a) Each capacitor holds a different amount of charge.  
 (b) The equivalent capacitance of the circuit is the sum of the individual capacitances.  
 (c) The total voltage supplied by the battery is the sum of the voltages across each capacitor.  
 (d) The total positive charge in the circuit is the sum of the positive charges on each capacitor.  
 (e) The total voltage supplied by the battery is equal to the average voltage across all the capacitors.
- 73. Three parallel plate capacitors, each having a capacitance of 1.0 μF are connected in parallel. The potential difference across the combination is 100 V. What is the equivalent capacitance of this combination?
- (a) 0.3 μF (c) 3 μF (e) 30 μF  
 (b) 1 μF (d) 6 μF
- 74. Three parallel plate capacitors, each having a capacitance of 1.0 μF are connected in parallel. The potential difference across the combination is 100 V. What is the charge on any one of the capacitors?
- (a) 30 μC (c) 300 μC (e) 3000 μC  
 (b) 100 μC (d) 1000 μC
- 75. A 3.0-μF capacitor is connected in series with a 4.0-μF capacitor and a 48-V battery. What quantity of charge is supplied by the battery to charge the capacitors?
- (a)  $3.4 \times 10^{-4}$  C (c)  $3.0 \times 10^{-5}$  C (e)  $1.8 \times 10^{-6}$  C

- (b)  $7.3 \times 10^{-4} \text{ C}$  (d)  $8.2 \times 10^{-5} \text{ C}$

76. What is the equivalent capacitance of the combination of capacitors shown in the circuit?

- (a)  $0.37 \mu\text{F}$  (d)  $0.67 \mu\text{F}$   
 (b)  $3.3 \mu\text{F}$  (e)  $2.1 \mu\text{F}$   
 (c)  $4.6 \mu\text{F}$

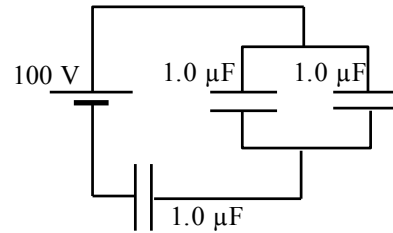

77. How much energy is stored in the combination of capacitors shown?

- (a) 0.01 J (d) 0.04 J  
 (b) 0.02 J (e) 0.05 J  
 (c) 0.03 J

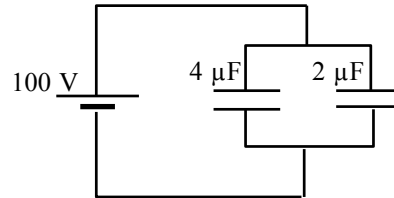

78. A battery supplies a total charge of  $5.0 \mu\text{C}$  to a circuit that consists of a series combination of two identical capacitors, each with capacitance  $C$ . Determine the charge on either capacitor.

- (a)  $5.0 \mu\text{C}$  (c)  $1.5 \mu\text{C}$  (e)  $0.50 \mu\text{C}$   
 (b)  $2.5 \mu\text{C}$  (d)  $1.0 \mu\text{C}$

79. When two capacitors are connected in series, the equivalent capacitance of the combination is  $100 \mu\text{F}$ . When the two are connected in parallel, however, the equivalent capacitance is  $450 \mu\text{F}$ . What are the capacitances of the individual capacitors?

- (a)  $200 \mu\text{F}$  and  $250 \mu\text{F}$  (d)  $150 \mu\text{F}$  and  $300 \mu\text{F}$   
 (b)  $125 \mu\text{F}$  and  $325 \mu\text{F}$  (e)  $80 \mu\text{F}$  and  $370 \mu\text{F}$   
 (c)  $175 \mu\text{F}$  and  $275 \mu\text{F}$

**Questions 80 through 82 pertain to the situation described below:**

A  $10.0\text{-}\mu\text{F}$  capacitor is charged so that the potential difference between its plates is  $10.0 \text{ V}$ . A  $5.0\text{-}\mu\text{F}$  capacitor is similarly charged so that the potential difference between its plates is  $5.0 \text{ V}$ . The two charged capacitors are then connected to each other in parallel with positive plate connected to positive plate and negative plate connected to negative plate.

80. How much charge flows from one capacitor to the other when the capacitors are connected?  
 (a)  $17 \mu\text{C}$  (c)  $67 \mu\text{C}$  (e) zero coulombs  
 (b)  $33 \mu\text{C}$  (d)  $83 \mu\text{C}$
81. What is the final potential difference across the plates of the capacitors when they are connected in parallel?  
 (a)  $5.0 \text{ V}$  (c)  $7.5 \text{ V}$  (e)  $10 \text{ V}$   
 (b)  $6.7 \text{ V}$  (d)  $8.3 \text{ V}$
82. How much energy is dissipated when the two capacitors are connected together?  
 (a)  $33 \mu\text{J}$  (c)  $63 \mu\text{J}$  (e)  $560 \mu\text{J}$   
 (b)  $42 \mu\text{J}$  (d)  $130 \mu\text{J}$

### Section 20.13 RC Circuits

83. A simple  $RC$  circuit consists of a  $1\text{-}\mu\text{F}$  capacitor in series with a  $3000\text{-}\Omega$  resistor, a  $6\text{-V}$  battery, and an open switch. Initially, the capacitor is uncharged. How long after the switch is closed will the voltage across the capacitor be  $3.8 \text{ V}$ ?

- (a)  $3 \times 10^9$  s  
 (b) 3 s  
 (c)  $3 \times 10^{-9}$  s  
 (d)  $3 \times 10^{-8}$  s  
 (e) 0.003 s

**Questions 84 and 85 pertain to the statement and diagram below:**

The figure shows a simple RC circuit consisting of a 100.0-V battery in series with a 10.0- $\mu$ F capacitor and a resistor. Initially, the switch S is open and the capacitor is uncharged. Two seconds after the switch is closed, the voltage across the resistor is 37 V.

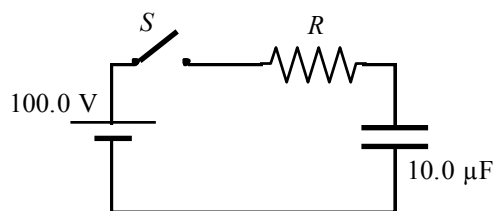

84. Determine the numerical value of the resistance  $R$ .
- (a) 0.37  $\Omega$   
 (b) 2.70  $\Omega$   
 (c)  $5.0 \times 10^4$   $\Omega$   
 (d)  $2.0 \times 10^5$   $\Omega$   
 (e)  $4.3 \times 10^5$   $\Omega$
85. How much charge is on the capacitor 2.0 s after the switch is closed?
- (a)  $1.1 \times 10^{-3}$  C  
 (b)  $2.9 \times 10^{-3}$  C  
 (c)  $3.7 \times 10^{-4}$  C  
 (d)  $5.2 \times 10^{-4}$  C  
 (e)  $6.6 \times 10^{-4}$  C

**Questions 86 through 88 pertain to the situation described below:**

An uncharged 5.0- $\mu$ F capacitor and a resistor are connected in series to a 12-V battery and an open switch to form a simple RC circuit. The switch is closed at  $t = 0$  s. The time constant of the circuit is 4.0 s.

86. Determine the value of the resistance  $R$ .
- (a) 15  $\Omega$   
 (b) 60  $\Omega$   
 (c)  $8.0 \times 10^5$   $\Omega$   
 (d)  $8.0 \times 10^7$   $\Omega$   
 (e)  $8.0 \times 10^8$   $\Omega$
87. Determine the maximum charge on the capacitor.
- (a)  $6.0 \times 10^{-5}$  C  
 (b)  $9.5 \times 10^{-5}$  C  
 (c)  $1.5 \times 10^{-5}$  C  
 (d)  $4.8 \times 10^{-5}$  C  
 (e)  $5.5 \times 10^{-5}$  C
88. What is the charge remaining on either plate after one time constant has elapsed?
- (a)  $7.4 \times 10^{-5}$  C  
 (b)  $5.5 \times 10^{-5}$  C  
 (c)  $1.2 \times 10^{-5}$  C  
 (d)  $3.8 \times 10^{-5}$  C  
 (e)  $2.2 \times 10^{-5}$  C

**Questions 89 through 91 pertain to the situation described below:**

The figure shows a simple RC circuit consisting of a 10.0- $\mu$ F capacitor in series with a resistor. Initially, the switch is open as suggested in the figure. The capacitor has been charged so that the potential difference between its plates is 100.0 V. At  $t = 0$  s, the switch is closed. The capacitor discharges exponentially so that 2.0 s after the switch is closed, the potential difference between the capacitor plates is 37 V. In other words, in 2.0 s the potential difference between the capacitor plates is reduced to 37 % of its original value.

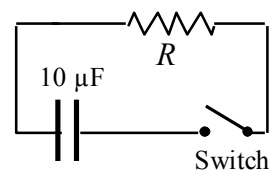

89. Calculate the electric potential energy stored in the capacitor before the switch is closed.
- (a) 0.01 J  
 (b) 0.02 J  
 (c) 0.03 J  
 (d) 0.04 J  
 (e) 0.05 J

- 90. Determine the potential drop across the resistor  $R$  at  $t = 2.0$  s (i.e., two seconds after the switch is closed).
- (a) zero volts (c) 63 V (e) 100 V  
 (b) 37 V (d) 87 V
- 91. Determine the numerical value of the resistance  $R$ .
- (a)  $1.0 \times 10^5 \Omega$  (c)  $5.0 \times 10^5 \Omega$  (e)  $2.5 \times 10^6 \Omega$   
 (b)  $2.0 \times 10^5 \Omega$  (d)  $1.0 \times 10^6 \Omega$

**Questions 92 through 95 pertain to the situation described below:**

An RC circuit consists of a resistor with resistance  $1.0 \text{ k}\Omega$ , a 120-V battery, and two capacitors,  $C_1$  and  $C_2$ , with capacitances of  $20.0 \mu\text{F}$  and  $60.0 \mu\text{F}$ , respectively. Initially, the capacitors are uncharged; and the switch is closed at  $t = 0$  s.

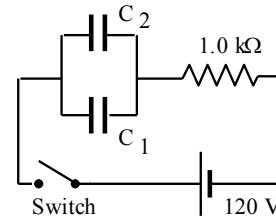

- 92. What is the current through the resistor *a long time* after the switch is closed? Recall that current is the charge per unit time that *flows* in a circuit.
- (a) 0.60 A (c) 0.24 A (e) zero amperes  
 (b) 0.12 A (d) 0.48 A
- 93. What is the time constant of the circuit?
- (a)  $1.0 \times 10^{-2}$  s (c)  $6.0 \times 10^{-2}$  s (e)  $3.0 \times 10^{-1}$  s  
 (b)  $2.0 \times 10^{-2}$  s (d)  $8.0 \times 10^{-2}$  s
- 94. How much charge will be stored in each capacitor after a long time has elapsed?
- | Charge on $C_1$            | Charge on $C_2$        |
|----------------------------|------------------------|
| (a) $2.4 \times 10^{-3}$ C | $7.2 \times 10^{-3}$ C |
| (b) $1.8 \times 10^{-3}$ C | $1.8 \times 10^{-3}$ C |
| (c) $6.0 \times 10^{-3}$ C | $2.0 \times 10^{-3}$ C |
| (d) $9.6 \times 10^{-3}$ C | $9.6 \times 10^{-3}$ C |
| (e) zero coulombs          | zero coulombs          |
- 95. Determine the total charge on both capacitors two time constants after the switch is closed.
- (a)  $1.3 \times 10^{-3}$  C (c)  $4.7 \times 10^{-3}$  C (e)  $8.3 \times 10^{-3}$  C  
 (b)  $2.2 \times 10^{-3}$  C (d)  $6.1 \times 10^{-3}$  C